

LXT/LXW Technical Data

Electric Tractor and Platform Truck

[LXT 120/Li-Ion](#)

[LXT 180/Li-Ion](#)

[LXT 250/Li-Ion](#)

[LXT 250L/Li-Ion](#)

[LXT 300/Li-Ion](#)

[LXT 350/Li-Ion](#)

[LXW 20/Li-Ion](#)

[LXW 30/Li-Ion](#)





				STILL	STILL	STILL	STILL	STILL	STILL	STILL	STILL
				LXT 120/Li-Ion	LXT 180/Li-Ion	LXT 250/Li-Ion	LXT 250L/Li-Ion	LXT 300/Li-Ion	LXT 350/Li-Ion	LXW 20/Li-Ion	LXW 30/Li-Ion
Features	1.1	Manufacturer									
	1.2	Manufacturer's type designation									
	1.3	Drive			Electric	Electric	Electric	Electric	Electric	Electric	Electric
	1.4	Operation			Seated	Seated	Seated	Seated	Seated	Seated	Seated
	1.5	Load capacity/load	Q	kg	300	300	300	300	300	300	3000
	1.5.1	Towing capacity	Q	kg	12000	18000	25000	25000	30000	35000	6000
	1.7	Rated drawbar pull	F	N	2400	3600	5000	5000	6000	7000	900/1200
	1.9	Wheel base	y	mm	1408	1408	1551	1906	1906	2156	1906
	Weights	2.1	Service weight incl. battery			kg	3883	3883	4450	5250	6000
2.2		Axle load, laden	front/rear	kg	2079/2104	2079/2104	2900/1850	2928/2622	2928/2622	3220/3080	2620 ¹ /3585 ¹
2.3		Axle load, unladen	front/rear	kg	2010/1873	2010/1873	2780/1670	2808/2442	2808/2442	3150/2850	2320 ¹ /1885 ¹
Wheels/chassis	3.1	Tyres				Pneumatic/superelastic	Pneumatic/superelastic	Pneumatic/superelastic	Pneumatic/superelastic	Pneumatic/superelastic	Pneumatic/superelastic
	3.2	Tyre size	front		6.00 R 9	6.00 R 9	6.00 R 9	6.00 R 9	6.00 R 9	6.00 R 9	6.00 R 9
	3.3	Tyre size	rear		7.00 R 12	7.00 R 12	7.00 R 12	7.00 R 12	7.00 R 12	7.00 R 12	7.00 R 12
	3.5	Number of wheels (x = driven)	front/rear		2/2x	2/2x	2/2x	2/2x	2/2x	2/2x	2/2x
	3.6	Track width, front	pneumatic/superelastic	b ₁₀	mm	1102/1120	1102/1120	1102/1120	1102/1120	1102/1120	1102/1120
	3.7	Track width, rear		b ₁₁	mm	1060	1060	1060	1060	1060	1060
	4.7	Height to top of overhead guard, (cabin)		h ₆	mm	1950	1950	1950	1950	1950	1950
Basic dimensions	4.8	Seat height rel. to SIP/stand height		h ₇	mm	907	907	907	907	907	907
	4.12	Coupling height		h ₁₀	mm	270, 330, 380, 440 (RO244)	270, 330, 380, 440 (RO244)	270, 330, 380, 440 (RO244)	345 (HSM 2140)	345 (HSM 2140)	345 (HSM 2140)
	4.13	Loading height unladen		h ₁₁	mm	1060	1060	1060	1060	1060	897
	4.16	Length of loading platform		l ₃	mm	1396	1396	1540	1895	2145	2200/2600 ²
	4.17	Cabin overhang		l _{5.1}	mm	1055	1055	1055	1055	1055	1055
	4.17.1	Rear overhang		l ₅	mm	624	624	624	707	707	665 (1065 ²)
	4.18	Width of loading platform		b ₉	mm	1056-1176	1056-1176	1056-1176	1056-1176	1056-1176	1300
	4.19	Overall length		l ₁	mm	3086	3086	3230	3668	3918	3626/4026 ²
	4.21	Overall width		b ₁ /b ₂	mm	1310	1310	1310	1310	1310	1310
	4.32	Ground clearance, centre of wheel base		m ₂	mm	150	150	150	150	150	150
	4.34	Working aisle width without safety distance/safety margin		A _{st}	mm	4500	4500	4696	5230	5603	5371/5613 ²
	4.35	Turning radius	front/rear	W _a	mm	2737/1563	2737/1563	2884/1612	3280/1750	3280/1750	3539/1864
	4.36	Smallest pivot point distance		b ₁₃	mm	881	881	931	1071	1071	1187
Performance data	5.1	Driving speed	laden/unladen	km/h	15/22	17/23	18/25	20/25	20/25	20/25	18/20
	5.5	Drawbar pull, unladen		N	2400	3600	5000	5000	6000	7000	900/1200
	5.6	Max. drawbar pull, unladen		N	12000	15000	18000	18000	20000	21500	15000
	5.10	Service brake			Electric/hydraulic	Electric/hydraulic	Electric/hydraulic	Electric/hydraulic	Electric/hydraulic	Electric/hydraulic	Electric/hydraulic
Drive	6.1	Drive motor, rating KB 60 min		kW	2 x 10.5 kW	2 x 10.5 kW	2 x 10.5 kW	2 x 10.5 kW	2 x 10.5 kW	2 x 10.5 kW	2 x 10.5 kW
	6.3	Battery according to DIN 43531/35/36 A, B, C, no			43536 A	43536 A	43536 A	43536 A	43536 A	43536 A	43536 A
	6.4	Battery voltage		V	80	80	80	80	80	80	80
	6.4.1	Battery designation	min./max.	K _s	Ah	465	465	620	775/930	775/930	240/500
	6.5	Battery weight			kg	1238	1238	1210/1558	1863/2178	1863/2178	2785
	6.6	Energy consumption in accordance with EN 16796			kWh/h	5.82	6.79	8.73	7.76	9.69	10.66
Miscellaneous	8.1	Type of drive control				STILL MCU 3	STILL MCU 3	STILL MCU 3	STILL MCU 3	STILL MCU 3	STILL MCU 3
	10.7	Sound pressure level L _{pAZ} (operator's ear)			dB(A)	62	62	62	62	62	60
	10.8	Trailer coupling, item/DIN type				Rockinger 244	Rockinger 244	Rockinger 244	Type HSM 2140	Type HSM 2140	Type HSM 2140

¹ With platform 2200 mm

² Optionally with platform 2600 mm

LXT/LXW Electric Tractor and Platform Truck
 Technical Drawings

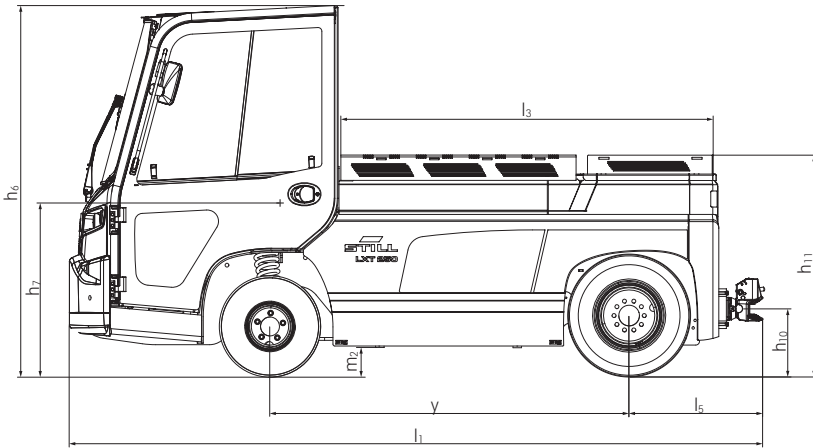

LXT Side view

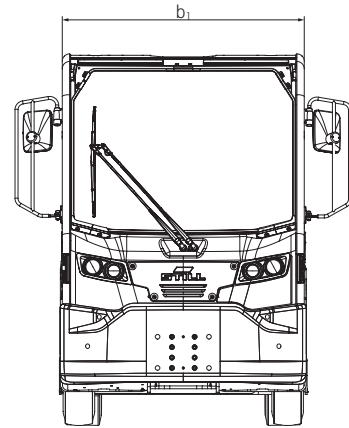

LXT Front view

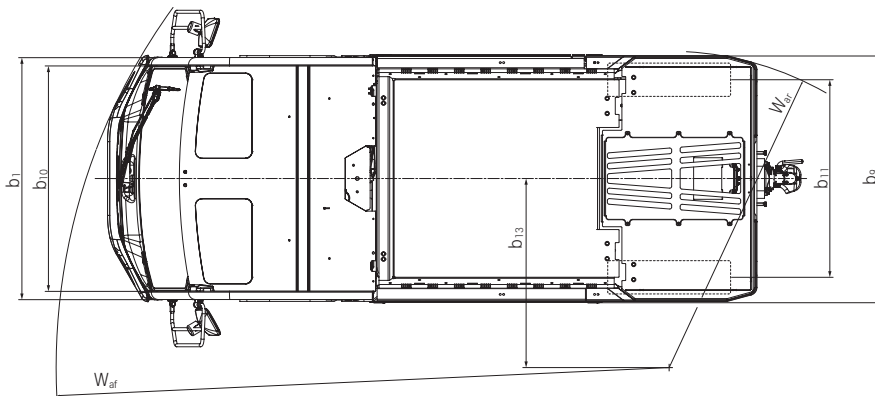

LXT Top view

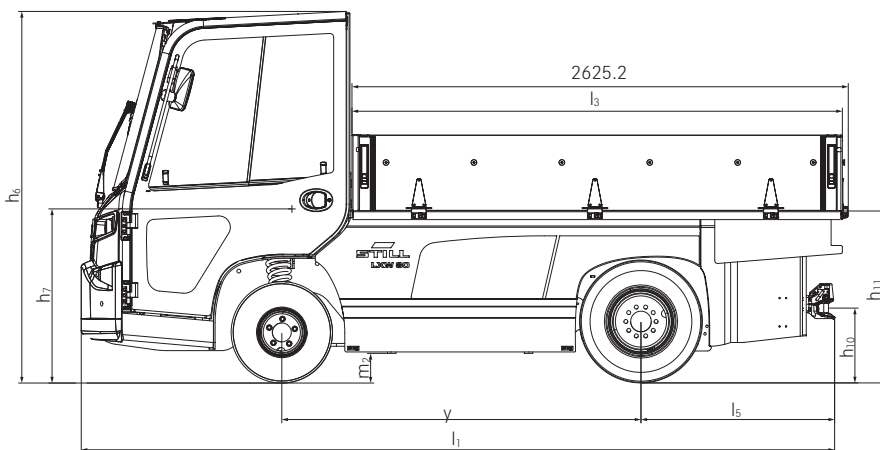

LXW Side view

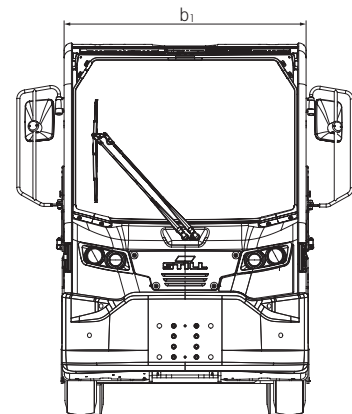

LXW Front view

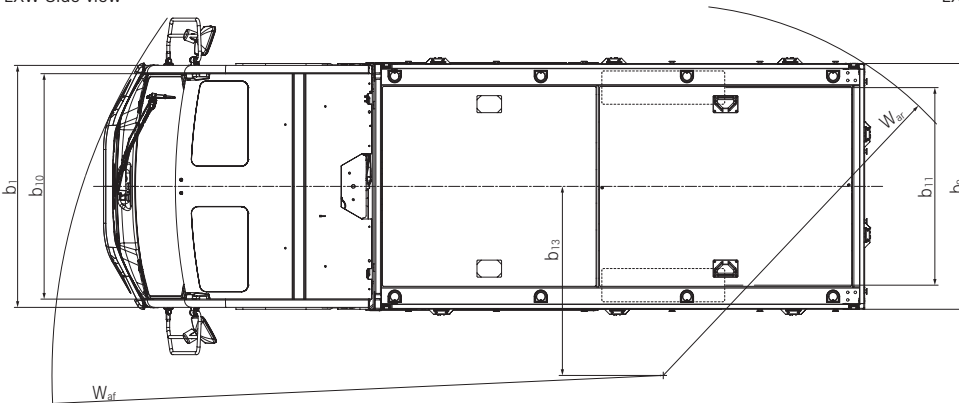

LXW Top view

LXT/LXW Electric Tractor and Platform Truck Performance Diagram

LXT 120

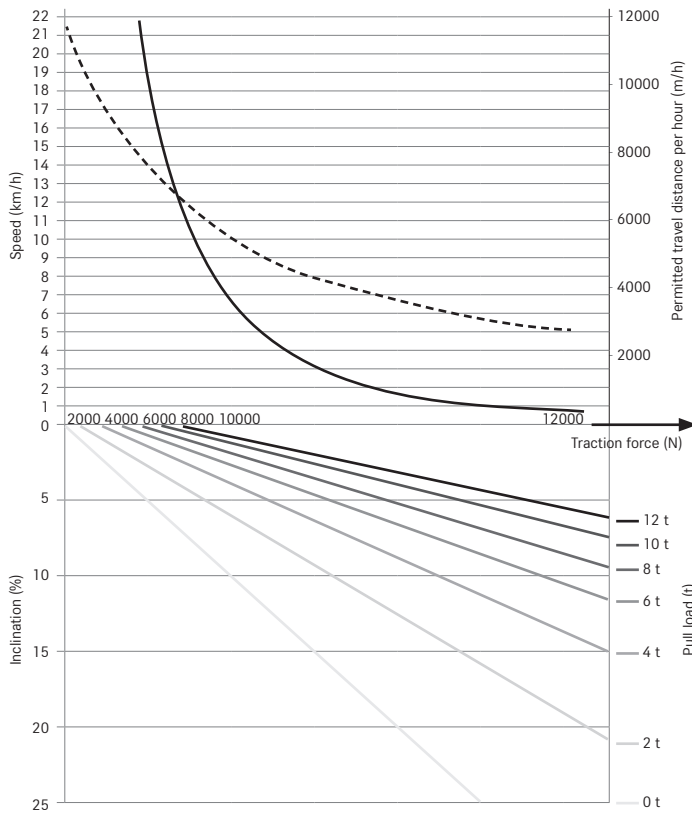

LXT 180

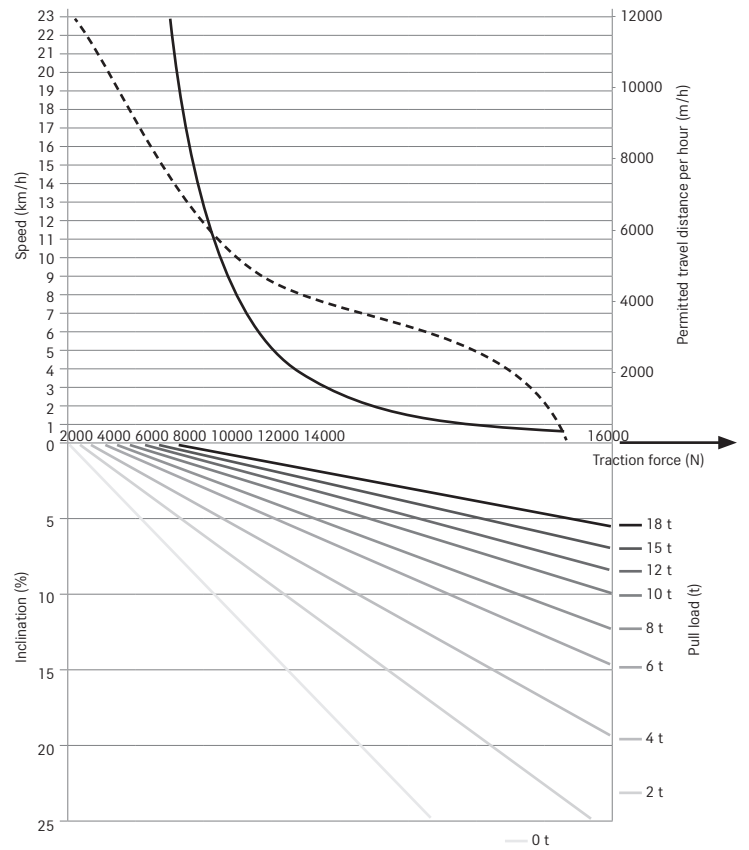

LXT 250

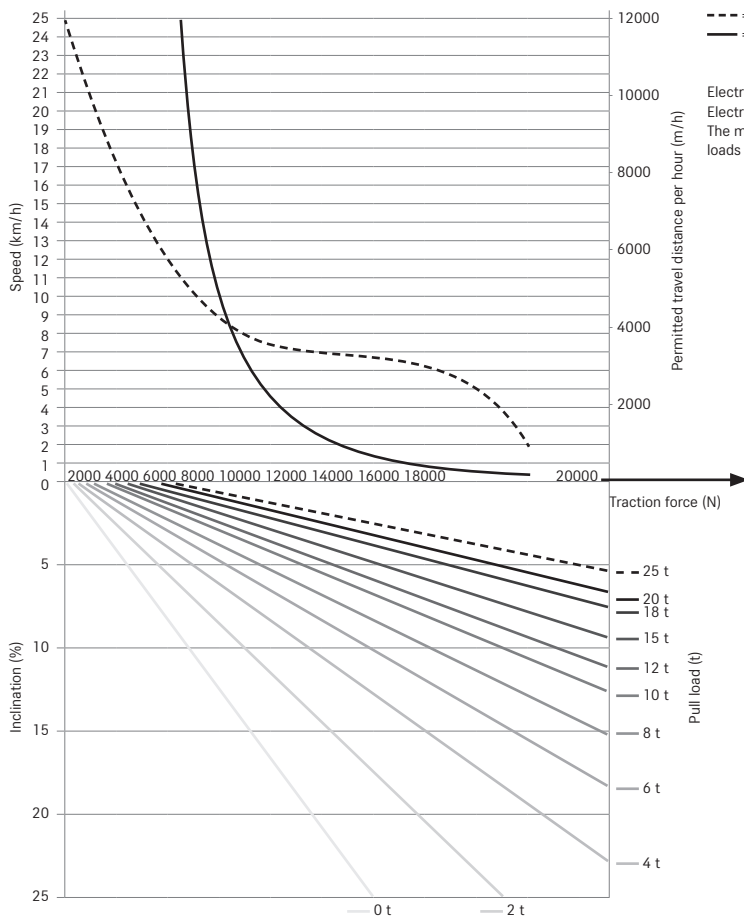

--- = Speed
 — = Permitted travel distance per hour

Electric platform truck LXW: It is recommended to use braked trailers only.
 Electric tractor LXT: It is recommended to use unbraked trailers only for towing on level ground.
 The maximum loads for unbraked trailers are shown in the table below.
 loads for unbraked trailers shown in the following table.

LXT/LXW Electric Tractor and Platform Truck Performance Diagram

LXT 300

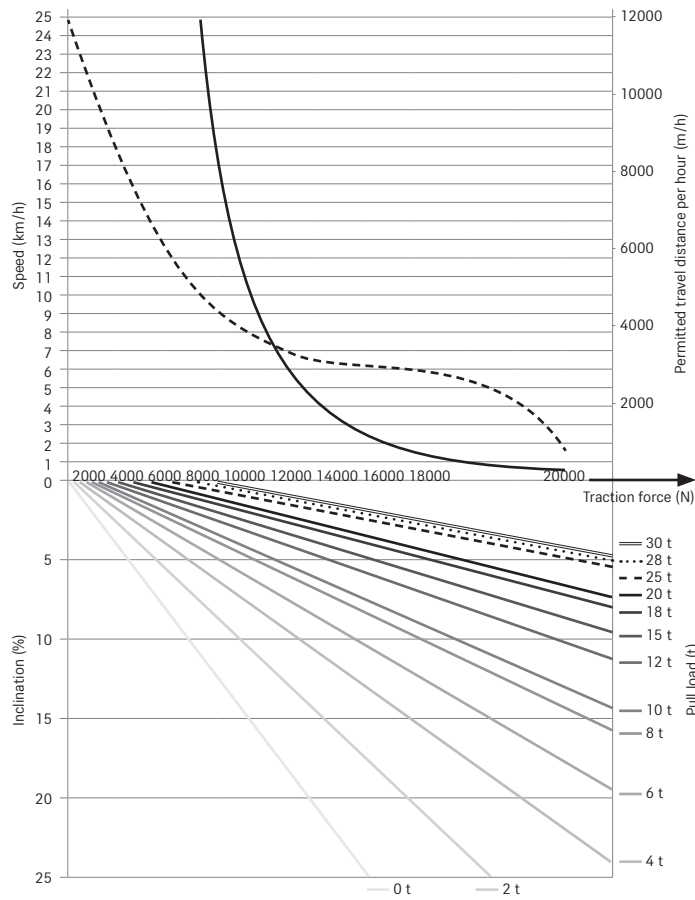

LXT 350

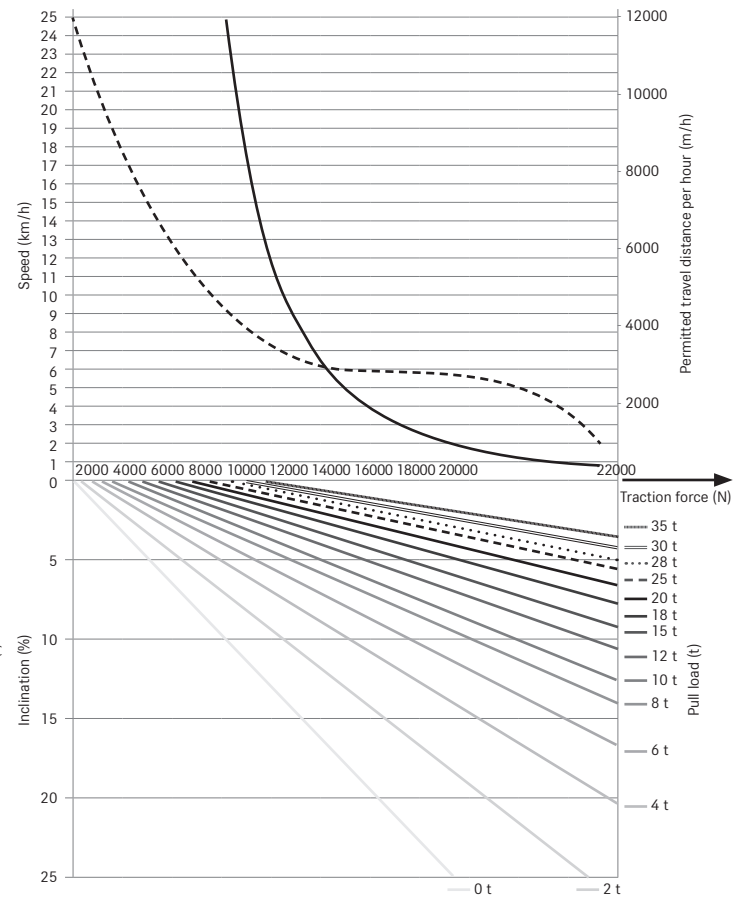

LXW 20/30

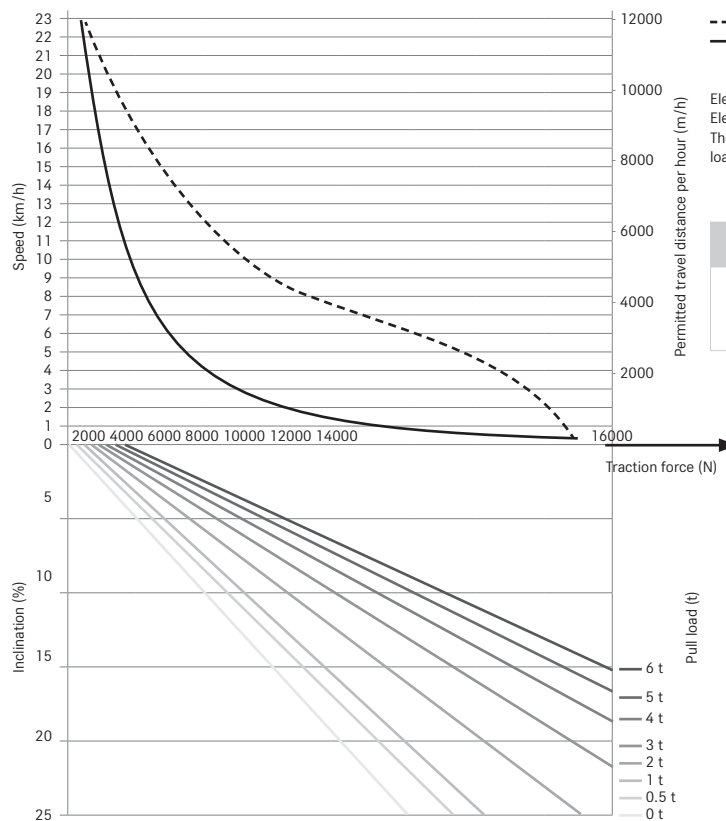

--- = Speed
 — = Permitted travel distance per hour

Electric platform truck LXW: It is recommended to use braked trailers only.
 Electric tractor LXT: It is recommended to use unbraked trailers only for towing on level ground.
 The maximum loads for unbraked trailers are shown in the table below.
 loads for unbraked trailers shown in the following table.

	LXT 120	LXT 180	LXT 250/ 250L	LXT 300	LXT 350
Maximum recommended unbraked trailer load	4 t	7 t	10 t	11 t	12 t

LXT/LXW Electric Tractor and Platform Truck Detailed Photos



The optional STILL Flashlight, securely installed below the roof, provides a warning for people in front of and behind the truck



The optional roof window provides an unobstructed view upwards and additional ventilation



Safe and fast charging without opening the battery door thanks to the optional quick charging flap



The robust operator's cabin is spacious and can be flexibly configured, e.g. with different doors or additional mirrors



The optional temperature control creates a consistently pleasant climate in the operator's cabin

LXT/LXW Electric Tractor and Platform Truck Detailed Photos



Working comfort in a class of its own with optional MSG 75 air sprung seat:
Superior suspension on cushioned and sprung chassis



The smooth-running steering wheel with knob ensures top ergonomics. The operator also has an overview of all the available information on a large display



Lateral battery changing as standard, for easy and safe replacement without the need for a crane



Optional vertical battery changing also available for many truck types

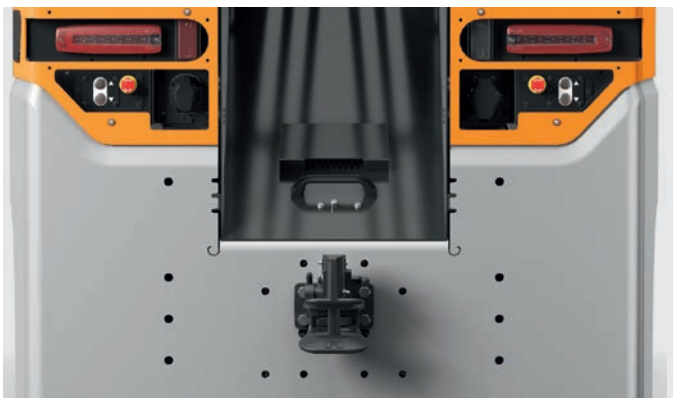

Reversing devices at the rear ensure safe and efficient coupling and decoupling



Simply easy

- Constant overview of all relevant information thanks to the large, colour STILL Easy Control display with many individual setting options
- Ready for use at all times: quick and easy charging and interim charging anytime and anywhere with the quick charging socket and on-board charger



Simply powerful

- Pulls up to 35 tonnes trailing load thanks to powerful twin-engine drive
- Ideally prepared for harsh working environments thanks to robust protection devices for the truck and many of its components



Simply safe

- Efficient and safe on any ramp: the unique Descent Speed Regulation (DSR) assistance system automatically regulates travel speed depending on load and tilting angle
- Numerous windows, telescopic mirrors and a rear-view camera ensure safe driving with the best all-round visibility



Simply flexible

- Versatile application possibilities due to the modular vehicle portfolio and a multitude of individual equipment variants



Simply connected

- Uncomplicated integration of the truck into control systems such as STILL neXXt fleet via an optional interface
- Access protection guarantees complete usage control, safety and damage minimisation

Simply Efficient



LXT/LXW Electric Tractor and Platform Truck Efficiency in action

Descent Speed Regulation: safe travel on ramps with speed regulation that responds to the load and inclination angle

Safe all-round warning with STILL Flashlight installed within the truck contour without elevation

Versatile application possibilities due to the extensive vehicle portfolio with 12 to 35 tonnes tractive force and many equipment options

Everything at a glance thanks to STILL Easy Control and the colour multifunction display with individual assignment options



Efficiency in action: an extensive truck portfolio, wide range of modular equipment options and impressive performance. The LXT 120/350 and LXW 20/30 tractors and transport vehicles are impressive even in rough environments and prove that efficiency and top performance can be perfectly combined. The DSR (Descent Speed Regulation) assistance system even takes your handling capacity to a new level: As soon as you reach a slope, the truck determines the exact tilt angle, takes into account the current load weight and automatically adjusts the speed to the current conditions. The result: with towing loads of up to 35 tonnes, you can adapt to any situation while moving as quickly as possible at the same time! The tractors and transport vehicles can

be charged quickly and easily without opening the cover thanks to the quick charging socket or on-board charger. However, this is surprisingly rarely necessary thanks to its impressive energy efficiency. When in use, the smart STILL Easy Control on-board computer is your control centre. The large display provides an overview of all the relevant information, while functions such as various driving programmes are activated by the click of a button. And as if the prospect of a safe, smart and speedy goods flow weren't enough to tick your boxes, just wait until you've tried out the comfortable ergonomics and dynamic driving experience.

Descent Speed Regulation

The optional Descent Speed Regulation (DSR) assistance system ensures safe travel on ramps at all times with automatic speed regulation which is dependent on the current load and tilting angle.

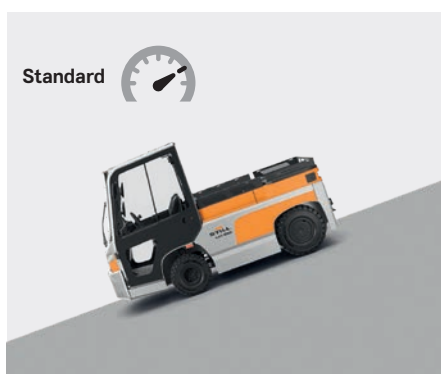

Basic: previously set speed on descent is manually limited via the switch.



Eco: gradient shown on the display, previously set speed is limited to a predefined value when a gradient is detected.



Premium: gradient shown on the display, speed reduction depending on load and gradient.

LXT/LXW Electric Tractor and Platform Truck Equipment Variants



		LXT 120/ LXT 180	LXT 250	LXT 250L/ LXT 300	LXT 350	LXW 20/ LXW 30
Cabin	Steel overhead guard with open design	●	●	●	●	●
	Weatherproof cabin	○	○	○	○	○
	Weatherproof cabin with strap opening	○	○	○	○	○
	Tarpaulin cabin	○	○	○	○	○
	Full cabin	○	○	○	○	○
	Full cabin with sliding doors	○	○	○	○	—
Assistance systems	Descent Speed Regulation Basic	●	●	●	●	●
	Descent Speed Regulation Eco	○	○	○	○	○
	Descent Speed Regulation Premium	○	○	○	○	○
	Load measurement and load display	○	○	○	○	○
	Rear-view camera	○	○	○	○	○
	Reversing device	●	●	●	●	○
Energy	Lithium-ion version	○	○	○	○	○
	On-board charger	○	○	○	○	○
	Lateral battery change	●	●	●	●	●
	Crane-loadable battery change	○	○	○	—	—
Towing coupling	3-stage coupling at the rear	○	○	—	○	—
	Rockinger 244A, rear	●	●	—	—	●
	HSM 2140, rear	○	○	●	●	○
	Trailer coupling at front	○	○	○	○	○
Platform	Tugger train hydraulics	○	○	○	○	—
	Rail 100 mm high	●	●	●	●	—
	Rail 350 mm high	○	○	○	○	—
	Lashing eyes	—	—	—	—	●
	Rail, hinged	—	—	—	—	○
Tyres	Tarpaulin roof arch construction	—	—	—	—	○
	Pneumatic tyres	●	●	●	—	●
Operator's cab equipment	Super elastic tyres	○	○	○	●	○
	Steering wheel with knob	○	○	○	○	○
	Courtesy light	○	○	○	○	○
	Heating and air-conditioning	○	○	○	○	○
	Radio with Bluetooth	○	○	○	○	○
	Heated front windscreen	○	○	○	○	○
	Right-hand drive or left-hand drive	○	○	○	○	○
	STILL Easy Control multifunction display	●	●	●	●	●
Lights and protection	Emergency vehicle lighting	○	○	○	○	○
	Flashing light	○	○	○	○	○
	STILL Flashlight: flashing light below the overhead guard	○	○	○	○	○
	Unbreakable/telescopic/heated exterior mirrors with curb mirrors	○	○	○	○	○
	Protection package for lights and frame	○	○	○	○	○
	Trucks are compliant with StVZO (German road traffic licensing regulations)	○	○	○	○	○
	FleetManager: access authorisation, shock detection, reports	○	○	○	○	○

● Standard ○ Option — Not available



STILL GmbH
Berzeliusstr. 10
22113 Hamburg
Germany
Tel.: +49 40 73 39 20 00
Fax: +49 40 73 39 20 01
info@still.de

**For further information please visit
www.still.eu**

STILL is certified in the following areas: Quality management, occupational safety, environmental protection and energy management.



first in intralogistics